

This Page Is Inserted by IFW Operations
and is not a part of the Official Record

BEST AVAILABLE IMAGES

Defective images within this document are accurate representations of the original documents submitted by the applicant.

Defects in the images may include (but are not limited to):

- BLACK BORDERS
- TEXT CUT OFF AT TOP, BOTTOM OR SIDES
- FADED TEXT
- ILLEGIBLE TEXT
- SKEWED/SLANTED IMAGES
- COLORED PHOTOS
- BLACK OR VERY BLACK AND WHITE DARK PHOTOS
- GRAY SCALE DOCUMENTS

IMAGES ARE BEST AVAILABLE COPY.

**As rescanning documents *will not* correct images,
please do not report the images to the
Image Problem Mailbox.**

(12) **EUROPEAN PATENT APPLICATION**

(21) Application number: 85112914.8

(51) Int. Cl.⁴: **H 01 L 41/08**
G 01 S 7/52

(22) Date of filing: 11.10.85

(30) Priority: 15.10.84 US 661082

(43) Date of publication of application:
21.05.86 Bulletin 86/21

(64) Designated Contracting States:
AT BE CH DE FR GB IT LI NL SE

(71) Applicant: Edo Corporation/Western Division
2645 South 300 West
Salt Lake City Utah 84115(US)

(72) Inventor: Lapetina, Robert A.
4196 Abinadi Road
Salt Lake City Utah 84117(US)

(72) Inventor: Snow, Gordon L.
2748 East 5141 South
Salt Lake City Utah 84117(US)

(72) Inventor: Balrd, P. David
1376 Lincoln Street
Salt Lake City Utah 84105(US)

(74) Representative: Patentanwälte Grünecker, Kinkeldey,
Stockmair & Partner
Maximilianstrasse 58
D-8000 München 22(DE)

(54) Flexible piezoelectric transducer assembly.

(57) A flexible piezoelectric transducer assembly for producing sonar signals for transmission underwater and for detecting reflected sonar signals. The assembly includes a generally flat, flexible casing formed with a plurality of compartments, each of which is for receiving a piezoelectric element. A plurality of piezoelectric elements are disposed in each of the compartments and are coupled by way of conductors to electronic circuitry which produces electrical signals for stressing the piezoelectric elements and which processes electrical signals produced by the piezoelectric element in response to reflected sonar signals. The piezoelectric elements are spaced apart in the casing to allow flexing and bending, while also maintaining high packing density. The piezoelectric elements are also selected to have low cross-coupling characteristics.

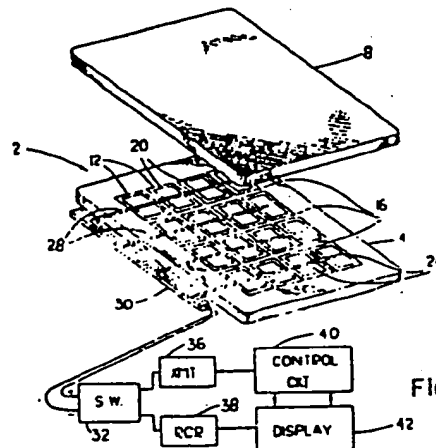

Fig. 1

1

5

10 FLEXIBLE PIEZOELECTRIC TRANSDUCER ASSEMBLY

This invention relates to a piezoelectric transducer assembly having an array of piezoelectric elements embedded or held in a flexible casing.

15

Piezoelectric elements, primarily crystals and ceramics, are employed in a variety of devices including crystal microphones, ultrasonic devices, accelerometers and oscillators. One of the most common uses of piezoelectric elements is in underwater sonar equipment in which a piezoelectric sonar transducer is stimulated by electrical signals to emit sonar signals which radiate out from the transducer. The sonar signals are reflected from underwater objects and the reflected signals are detected by the transducer which produces electrical signals carrying information about the underwater objects.

25

1 Transducers typically used in underwater sonar
equipment consist of either a single crystal or
ceramic element or a rigid array of elements. It
has been recognized that it would be desirable to
5 have a flexible, conformable transducer which
could be placed on various shaped surfaces for
use. If a rigid transducer were applied to such
surfaces and the surfaces were flexed or bent to
any extent, the transducer could be damaged. A
10 flexible, conformable transducer, however, would
not only allow for ease of attachment to different
shaped surfaces, but would also accommodate flexing
and bending of the surface on which the transducer
was placed.

15

There have been a number of proposals for providing
flexible transducers including grinding up of
piezoelectric material, embedding the material in
an elastic material, and then attempting to polarize
20 the entire unit so that it will function as a
piezoelectric device. This type of unit, however,
is typically very difficult to manufacture, sensitive
to hydrostatic pressure changes and lacking in
uniformity. Also, it is difficult to achieve
25 consistency of characteristics from one unit to
the next.

1 It is an object of the invention to provide a piezoelectric transducer assembly which is flexible and conformable to surfaces on which the assembly may be placed.

5

It is also an object of the invention to provide such an assembly which is easy to manufacture and whose quality can be readily controlled.

10 It is a further object of the invention to provide a piezoelectric transducer which is fairly immune to high pressures.

15 It is an additional object of the invention to provide a generally planar or linear, flexible piezoelectric transducer which can be shaped to focus or direct the sonar beams produced by the transducer as desired.

20 The above and other objects of the invention are realized in an illustrative embodiment of a flexible piezoelectric transducer assembly which includes an encasement made of a flexible, resilient material and having a generally flat profile, where the
25 encasement includes a number of compartments spaced apart generally in a plane in the encasement. Also included are a plurality of piezoelectric

1 elements, each disposed in a different compartment
of the encasement, and flexible conductors or
conductive coatings which are arranged to extend
through the encasement into contact with the
5 elements for carrying externally generated electrical
signals to the elements to stress the elements,
and for carrying to a signal processor or other
utilization device electrical signals produced by
the piezoelectric elements when the elements are
10 stressed.

With the above construction, the encasement holding
the piezoelectric elements may be flexed or bent
to conform to different mounting surface shapes.
15 Advantageously, each piezoelectric element is
polarized prior to installation in the encasement
and so manufacture of the transducer assembly is
simplified. A variety of materials might be used
for the encasement including polyurethane, polyethelene,
20 neoprene rubber, etc.

In the drawings:

The above and other objects, features and advantages
25 of the invention will become apparent from a
consideration of the following detailed description
presented in connection with the accompanying
drawings in which:

1 FIG. 1 shows a perspective, exploded view of
a flexible planar piezoelectric transducer
assembly made in accordance with the principles
of the present invention;

5

FIG. 2 is a side, fragmented cross-sectional
view of the piezoelectric transducer assembly
of FIG. 1;

10

FIG. 3 is a top, plan, fragmented view of the
base portion of a flexible piezoelectric
transducer assembly showing triangular-shaped
piezoelectric elements;

15

FIG. 4 is a side, fragmented cross-sectional
view of a flexible piezoelectric transducer
assembly which utilizes conductive sheets for
carrying electrical signals to and from the
piezoelectric elements;

20

FIG. 5 is a side, partially cutaway view of a
line-array piezoelectric transducer assembly
made in accordance with the principles of the
present invention;

25

FIG. 6 is a perspective view of an alternative
embodiment of a piezoelectric element which
could be used in the assembly of FIG. 5; and

1 FIG. 7 is a perspective view of still another
embodiment of a piezoelectric element which
could be used in the FIG. 5 assembly.

5 Referring now to the drawings:

Referring to FIG. 1, there is shown an illustrative
embodiment of a flexible planar piezoelectric
transducer assembly which includes a two-piece
10 housing or casing 2 having a base section 4 and a
cover section 8. Both sections are made of a
flexible, resilient material such as polyurethane,
polyethelene, neoprene rubber, etc. When the
cover section 8 is placed over and secured to the
15 base section 4, the casing will present a generally
flat profile as best seen in FIG. 2. The cover
section 8 may be secured to the base section 4 by
a suitable bonding agent such as polyurethane.
The casing is formed to be generally square, but
20 could take other shapes such as rectangular,
circular, triangular, etc.

Formed in the base section 4 of the casing are a
plurality of generally rectangular compartments
25 12. These compartments are formed to be fairly
closely packed and nested in the manner shown in
FIG. 1 to provide precise spacing of piezoelectric

1 elements (to be discussed momentarily). Adjacent
compartments are separated by walls 16 integrally
formed in the base section 4. Alternatively, a
single large hollow or compartment may be formed
5 in the base section 4 and then the piezoelectric
elements (to be discussed momentarily) positioned
in the hollow, separated from one another and held
in place by an adhesive.

10 A plurality of piezoelectric elements 20, either
crystal or ceramic, are also provided, with each
piezoelectric element being placed in a different
one of the compartments and held in place by an
adhesive. The piezoelectric elements 20 are
15 formed to fit snugly in each compartment and thus,
for the embodiment of FIG. 1, the elements are
shown as having a generally rectangular shape to
conform to the shape of the compartments. The
elements 20 have a thickness which is greater than
20 the depth of the compartments, such thickness
being less than the length and width of the elements.

Thin conductive films 24 are placed on the upper
and lower surfaces of each of the piezoelectric
25 elements 20 (advantageously during manufacture of
the elements) to enable poling of the elements
during manufacture and to serve as electrodes for

- 1 applying electrical signals to the elements. Such films could be any suitable conductive material such as silver, a silver alloy, etc.
- 5 The piezoelectric elements 20 are selected to possess low cross-coupling to thereby reduce response in unwanted modes of operation and enable use of the elements over a wide band of frequencies without significant sensitive degradation. Suitable
- 10 piezoelectric material for achieving this characteristic include lead mataniobate and lead titanate, among others.

Conductive strips of material 28 are placed in

15 contact with each of the conductive films 24 on the upper surfaces of the piezoelectric elements 20, with conductive strips 28 extending through the casing to a bus 30 which is coupled to a transmit/receive switch 32. Conductive strips of

20 material 34 (see FIG. 2) are placed in contact with conductive films positioned on the bottom surfaces of each of the piezoelectric elements 20 to extend through the casing also to the bus 30.

The conductive strips 28 and 34 could advantageously

25 be strips of silver, copper, etc., held in contact with the conductive films by spot welding, soldering or conductive adhesive. Alternatively, the conductive

1 strips could be strips of flexible elastomer
containing conductive (e.g. silver) particles of
flakes. This latter arrangement would provide
desired flexibility.

5

An alternative to the two-piece housing or casing
2 of FIG. 1 would be a one-piece housing made, for
example, by first supporting the piezoelectric
elements, connecting wires, etc., in the desired
10 configuration (using suitable tooling fixtures),
and then encapsulating the entire array in the
encasement material.

The circuitry for producing electrical signals to
15 stress the piezoelectric elements 20, and for
detecting the occurrence of stress in the elements
includes, in addition to the transmit/receive
switch 32, a transmitter 36 and receiver and
signal processor 38 both connected to the switch
20 32, a control circuit 40 connected to the transmitter
36, and a display unit 42 connected to the control
circuit 40 and receiver and signal processor 38.

The control circuit 40, which might illustratively
be a microprocessor, signals the transmitter 36 to
25 apply electrical signals via the transmit/receive
switch 32 to the piezoelectric elements 20 to
stress the elements. The piezoelectric elements

1 20 are thus caused to produce, for example, sonar
signals for underwater transmission. Reflected
sonar signals intercepted by the piezoelectric
elements 20 stress the elements and cause them to
5 produce electrical signals which are applied via
the switch 32 to the receiver and signal processor
38. The receiver and signal processor 38 process
these signals and then signals the display unit to
display information representing the location and
10 shape, for example, of underwater objects from
which the sonar signals are reflected. The
circuitry described is conventional, shown only
for illustrative purposes, and does not form any
part of the invention.

15

The overall size of the transducer assembly could
be whatever is desired by the user, but would
depend in part on the number of piezoelectric
elements to be utilized. Advantageously, the
20 piezoelectric elements 20 would have widths and
lengths of between about $1/8$ of an inch and several
inches, and would have thicknesses of between
about $1/100$ of an inch and 1 inch. These dimensions
facilitate ease of manufacture and piezoelectric
25 poling. Of course, the smaller the piezoelectric
element, the greater would be the flexibility and
conformability of the transducer assembly. Employment

1 of a flexible casing 2 for holding the piezoelectric
elements serves not only to accommodate the feature
of flexibility and conformability, but also serves
to isolate and protect the piezoelectric elements
5 20 from shock, hydrostatic pressures, water and
other fluids in which it would be used, and other
external effects. With the generally flat profile
of the transducer assembly, the assembly can be
readily attached to flat mounting surfaces and to
10 surfaces having shapes which are other than planar
and which may change over time.

FIG. 2 shows a side, fragmented cross-sectional view
of the transducer assembly of FIG. 1 including the
15 base section 4 and cover section 8 of the casing,
the piezoelectric elements 20, and a conductive
strip 28 attached to the conductive films or
electrodes 24 on the top surface of the piezoelectric
elements, and a conductive strip 34 attached to
20 the conductive films or electrodes on the bottom
surface of the elements.

FIG. 3 shows a top plan view of a fragmented
portion of a base section 44 of a casing, where
25 the compartments 48 are formed in a triangular
shape to accommodate triangularly-shaped piezoelectric
elements. Of course, a variety of other shapes

1 could also be employed as earlier indicated. It
is desirable, however, that the piezoelectric
elements be closely packed and nested together and
this is accommodated by either the rectangular or
5 triangular shape.

FIG. 4 shows a side, fragmented cross-sectional
view of a transducer assembly wherein sheets of
conductive material 54 and 58 are respectively
10 placed to contact all of the individual conductive
films placed on the upper surfaces of the piezoelectric
elements, and to contact all of the films or
electrodes on the bottom surfaces of the elements.
These conductive sheets would be provided for
15 carrying externally produced signals simultaneously
to all of the piezoelectric elements, and for
carrying signals produced by all of the elements
simultaneously to an external sink. This provision
of conductive sheets of material is an alternative
20 to the conductive strips 28 and 34 shown in FIG.
1. Advantageously, the conductive sheets would be
made of a composition of conductive particles and
an elastomer, to provide flexibility for bending,
etc.

25

FIG. 5 shows a partially cutaway view of a line
array of piezoelectric elements 60 placed in a

1 flexible encapsulant 64 such as neoprene, polyurethane,
or fluid such as oil or isopar, all of which are
contained in a flexible hose or sleeve 68 made,
for example, of neoprene, polyurethane or vinyl.

5 The sleeve 68 and encapsulant 64 surround the
piezoelectric elements 60 to prevent water or
other fluid in which the line array is used from
reaching the elements. The piezoelectric elements
60 shown in the drawing are elongate bars having a
10 generally square cross-section, but they could be
formed as solid cylinders, hollow cylinders,
cubes of other shapes suitable for placement in a
line array. The top sides of the piezoelectric
elements 60 are coupled together by an electrical
15 conductor 72 while the bottom sides are similarly
coupled together by a conductor 76. These conductors
both carry electrical signals to the piezoelectric
elements 60 to stress the elements and cause them
to produce sonar signals, and carry away electrical
20 signals produced by the elements when the elements
are stressed by reflected sonar signals. The
conductors 72 and 76 would be coupled to circuitry
similar to that shown in FIG. 1. If radially
polarized solid cylinders were used as the piezoelectric
25 elements, the conductors would be coupled to
respective electrodes 80 and 84 disposed on opposite
sides of the cylinders as shown in FIG. 6. If

1 radially polarized hollow cylinders were used, the
conductors would be coupled to the inside and
outside surfaces of the cylinders as shown in FIG.
7.

5

It is to be understood that the above-described
arrangements are only illustrative of the application
of the principles of the present invention.

Numerous modifications and alternative arrangements
10 may be devised by those skilled in the art without
departing from the spirit and scope of the present
invention and the appended claims are intended to
cover such modifications and arrangements.

15

20

25

1

5

10

C L A I M S

1. A flexible piezoelectric transducer assembly comprising

15

an encasement made of a flexible, resilient material and having a generally flattened profile, said encasement including a plurality of compartments spaced apart generally in a plane in the encasement,

20

a plurality of piezoelectric elements selected to have low cross coupling characteristics, each encapsulated in a different compartment of the encasement, and

25

conduction means coupled through the encasement to the elements for carrying electrical signals to the elements to stress the elements, and for carrying electrical signals produced by the elements when the elements are stressed.

1 2. A transducer assembly as in Claim 1
wherein said encasement is formed of a generally
planar base section an upper side of which is
formed with said compartments, and a top section
5 for placement on the upper side of the base
section to enclose the compartments.

 3. A transducer assembly as in Claim 1
wherein said encasement is made of polyurethane.

10

 4. A transducer assembly as in Claim 1
wherein said encasement is made of polyethelene.

 5. A transducer assembly as in Claim 1
15 wherein said encasement is made of rubber.

 6. A transducer assembly as in Claim 1
wherein the compartments of the encasement holding
the piezoelectric elements are formed in a closely
20 packed and nested arrangement in the encasement.

 7. A transducer assembly as in Claim 6
wherein the compartments and piezoelectric elements
are generally polygonal in shape and dimensioned
25 so that the elements fit snugly in the compartments.

1 8. A transducer assembly as in Claim 7
wherein the compartments and piezoelectric elements
are generally rectangular in shape.

5 9. A transducer assembly as in Claim 7
wherein the compartments and piezoelectric elements
are generally triangular in shape.

10 10. A transducer assembly as in Claim 1
wherein the piezoelectric elements are generally
flattened, and are selected to have low cross-
coupling characteristics.

15 11. A transducer assembly as in Claim 10
wherein the piezoelectric elements are made of
lead titanate.

20 12. A transducer assembly as in Claim 10
wherein the piezoelectric elements are made of lead
metaniobate.

25 13. A transducer assembly as in Claim 1
wherein the piezoelectric elements are formed
generally in squares having a thickness of from
about one-hundredth to one inch, and a width of
from about one-eighth to about four inches.

1 14. A transducer assembly as in Claim 1
wherein the piezoelectric elements are held in
place in the compartments by an adhesive.

5 15. A transducer assembly as in Claim 1
wherein the conduction means comprises
 conductive sheets disposed on opposing sides
of piezoelectric elements, and
 conductive strips of material placed in
10 contact with the conductive sheets and extending
through the encasement to carry electrical signals
from an external source to the sheets, and from
the sheets to external electronics.

15 16. A transducer assembly as in Claim 15
wherein said conductive strips are composed of a
composition of conductive particles and elastomer.

 17. A transducer assembly as in Claim 1
20 wherein the conduction means comprises
 a first sheet of conductive material disposed
in contact with one side of each of the piezoelectric
elements,
 a second sheet of conductive material disposed
25 in contact with the other side of each of the
elements, and

1 conductors for carrying electrical signals
from an external source to the first and second
sheets of material, and from the first and second
sheets to external electronics.

5

18. A sonar transducer assembly comprising
a casing made of a flexible, resilient material
formed to have a thickness which is less than the
length and width thereof, and including a multiplicity
10 of compartments located in a side-by-side, nested
relationship generally in a planar array,

a multiplicity of piezoelectric elements,
each disposed in a different compartment and each
having top and bottom surfaces which are generally
15 parallel with each other and with the plane of the
casing, each element being poled in the thickness
direction and having low cross-coupling characteristics,

conductive sheets disposed on the top and
bottom surfaces of the elements, and

20 conductors extending through the casing to
contact the conductive sheets for carrying electrical
signals to the sheets to stress the elements and
cause them to emit sonar signals, and for carrying
electrical signals produced by the elements when
25 the elements intercept reflected sonar signals.

1

19. A flexible piezoelectric transducer assembly comprising

5

an array of spaced-apart piezoelectric elements arranged generally in a line and selected to have low cross-coupling characteristics,

10

conductor means coupled to the piezoelectric elements for carrying electrical signals thereto to stress the elements, and for carrying electrical signals produced by the elements when the elements are stressed,

15

means for supporting the piezoelectric elements in the array, and

means for preventing external access of fluid to the elements.

20

20. A transducer assembly as in Claim 19 wherein said supporting means comprises a sleeve means in which are disposed the piezoelectric elements.

25

21. A transducer assembly as in Claim 20 wherein the preventing means comprises a nonconductive encapsulant disposed about the piezoelectric elements to prevent access of fluid to the elements.

22. A transducer assembly as in Claim 19 wherein said piezoelectric elements comprise

1 elongate bars having top and bottom surfaces, and
wherein the conductor means comprise a pair of
conductors, one of which is coupled to the top
surfaces of each of the bars and the other of
5 which is coupled to the bottom surfaces.

23. A transducer assembly as in Claim 19
wherein said piezoelectric elements comprise
elongate cylinders polarized in the radial direction,
10 and wherein the conductor means comprise a pair of
conductors, each of which is coupled to a respective
opposing side surface of each of the cylinders.

24. A transducer assembly as in Claim 19
15 wherein said piezoelectric elements comprise
elongate, hollow cylinders polarized in the radial
direction, and having inside and outside surfaces,
and wherein the conductor means comprise a pair of
conductors, one of which is coupled to the outside
20 surfaces of each of the cylinders and the other of
which is coupled to the inside surfaces.

25. A transducer assembly as in Claim 21
wherein said encapsulant is a fluid.

25

26. A transducer assembly as in Claim 21
wherein said encapsulant is a flexible, resilient
material.

1/1

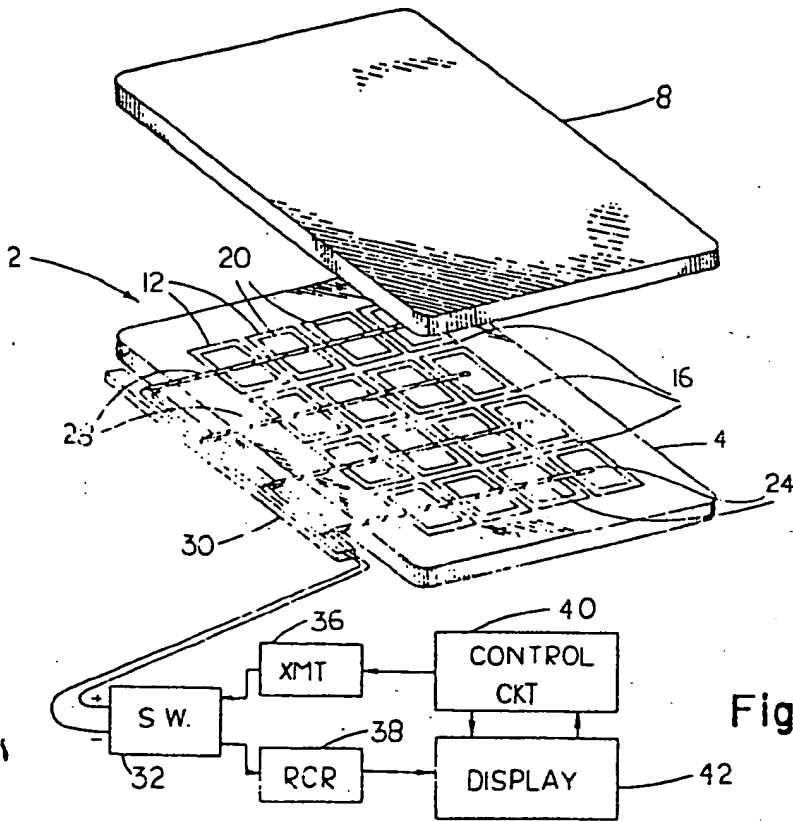

Fig. 1

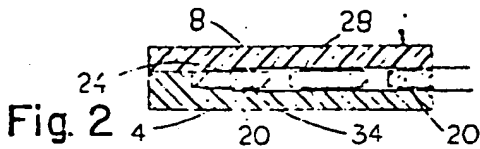

Fig. 2

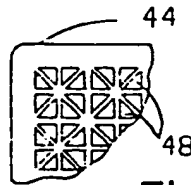

Fig. 3



Fig. 4

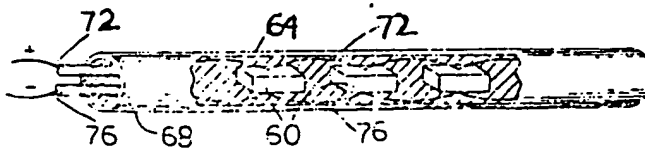

Fig. 5

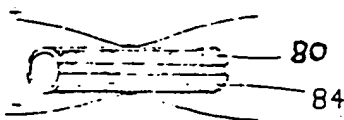

Fig. 6

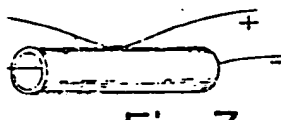

Fig. 7



EUROPEAN PATENT SPECIFICATION

- (45) Date of publication of patent specification: 21.08.91 (51) Int. Cl.⁵: H01L 41/08, G01S 7/52
(21) Application number: 85112914.8
(22) Date of filing: 11.10.85

(54) Flexible piezoelectric transducer assembly.

- (30) Priority: 15.10.84 US 661082
(43) Date of publication of application:
21.05.86 Bulletin 86/21
(45) Publication of the grant of the patent:
21.08.91 Bulletin 91/34
(64) Designated Contracting States:
AT BE CH DE FR GB IT LI NL SE
(56) References cited:
EP-A- 0 154 706 DE-A- 2 926 182
FR-A- 1 515 529 FR-A- 2 185 800
FR-A- 2 254 033 GB-A- 749 930

- (73) Proprietor: Edo Corporation/Western Division
2645 South 300 West
Salt Lake City Utah 84115(US)
(72) Inventor: Lapetina, Robert A.
4196 Abinadi Road
Salt Lake City Utah 84117(US)
Inventor: Snow, Gordon L.
2748 East 5141 South
Salt Lake City Utah 84117(US)
Inventor: Baird, P. David
1376 Lincoln Street
Salt Lake City Utah 84105(US)
(74) Representative: Patentanwälte Grünecker,
Kinkeldey, Stockmair & Partner
Maximilianstrasse 58
W-8000 München 22(DE)

Note: Within nine months from the publication of the mention of the grant of the European patent, any person may give notice to the European Patent Office of opposition to the European patent granted. Notice of opposition shall be filed in a written reasoned statement. It shall not be deemed to have been filed until the opposition fee has been paid (Art. 99(1) European patent convention).

Description

This invention relates to a piezoelectric transducer assembly having piezoelectric elements embedded or held in a flexible casing.

Piezoelectric elements, primarily crystals and ceramics, are employed in a variety of devices including crystal microphones, ultrasonic devices, accelerometers and oscillators. One of the most common uses of piezoelectric elements is in underwater sonar equipment in which a piezoelectric sonar transducer is stimulated by electrical signals to emit sonar signals which radiate out from the transducer. The sonar signals are reflected from underwater objects and the reflected signals are detected by the transducer which produces electrical signals carrying information about the underwater objects.

Transducers typically used in underwater sonar equipment consist of either a single crystal or ceramic element or a rigid array of elements. It has been recognized that it would be desirable to have a flexible, conformable transducer which could be placed on various shaped surfaces for use. If a rigid transducer were applied to such surfaces and the surfaces were flexed or bent to any extent, the transducer could be damaged. A flexible, conformable transducer, however, would not only allow for ease of attachment to different shaped surfaces, but would also accommodate flexing and bending of the surface on which the transducer was placed.

There have been a number of proposals for providing flexible transducers including grinding up of piezoelectric material, embedding the material in an elastic material, and then attempting to polarize the entire unit so that it will function as a piezoelectric device. This type of unit, however, is typically very difficult to manufacture, sensitive to hydrostatic pressure changes and lacking in uniformity. Also, it is difficult to achieve consistency of characteristics from one unit to the next.

From DE-A-29 26 182 an ultrasonic transducer assembly is known comprising a plurality of transducer elements closely disposed to each other in a common plane and sandwiched between an adaptor body and an attenuator body. The adaptor body and the attenuator body are made from flexible material so that the transducer assembly may be attached to an object having a curved surface. This transducer arrangement is adapted to be used in the nondestructive testing of material, it is not suitable for being used in underwater sonar equipment.

It is the object of the invention to provide a piezoelectric transducer assembly of the aforementioned kind which is easy to manufacture, the quality of which can be readily controlled, is fairly immune to high pressures and is susceptible to

being used in underwater sonar equipment

This object is attained by the features comprised in claim 1. Preferred embodiments of the invention are the subject matter of the dependent claims.

With the above construction, the encasement holding the piezoelectric elements may be flexed or bent to conform to different mounting surface shapes. Advantageously, each piezoelectric element is polarized prior to installation in the encasement and so manufacture of the transducer assembly is simplified. A variety of materials might be used for the encasement including polyurethane, polyethelene, neoprene rubber, etc.

In the drawings:

The above and other objects, features and advantages of the invention will become apparent from a consideration of the following detailed description presented in connection with the accompanying drawings in which:

FIG. 1 shows a perspective, exploded view of a flexible planar piezoelectric transducer assembly made in accordance with the principles of the present invention;

FIG. 2 is a side, fragmented cross-sectional view of the piezoelectric transducer assembly of FIG. 1;

FIG. 3 is a top, plan, fragmented view of the base portion of a flexible piezoelectric transducer assembly showing triangular-shaped piezoelectric elements; and

FIG. 4 is a side, fragmented cross-sectional view of a flexible piezoelectric transducer assembly which utilizes conductive sheets for carrying electrical signals to and from the piezoelectric elements;

Referring now to the drawings:

Referring to FIG. 1, there is shown an illustrative embodiment of a flexible planar piezoelectric transducer assembly which includes a two-piece housing or casing 2 having a base section 4 and a cover section 8. Both sections are made of a flexible, resilient material such as polyurethane, polyethelene, neoprene rubber, etc. When the cover section 8 is placed over and secured to the base section 4, the casing will present a generally flat profile as best seen in FIG. 2. The cover section 8 may be secured to the base section 4 by a suitable bonding agent such as polyurethane. The casing is formed to be generally square, but could take other shapes such as rectangular, circular, triangular, etc.

Formed in the base section 4 of the casing are a plurality of generally rectangular compartments 12. These compartments are formed to be fairly closely packed and nested in the manner shown in FIG. 1 to provide precise spacing of piezoelectric elements (to be discussed momentarily). Adjacent compartments are separated by walls 16 integrally

formed in the base section 4. Alternatively, a single large hollow or compartment may be formed in the base section 4 and then the piezoelectric elements (to be discussed momentarily) positioned in the hollow, separated from one another and held in place by an adhesive.

A plurality of piezoelectric elements 20, either crystal or ceramic, are also provided, with each piezoelectric element being placed in a different one of the compartments and held in place by an adhesive. The piezoelectric elements 20 are formed to fit snugly in each compartment and thus, for the embodiment of FIG. 1, the elements are shown as having a generally rectangular shape to conform to the shape of the compartments. The elements 20 have a thickness which is greater than the depth of the compartments, such thickness being less than the length and width of the elements.

Thin conductive films 24 are placed on the upper and lower surfaces of each of the piezoelectric elements 20 (advantageously during manufacture of the elements) to enable poling of the elements during manufacture and to serve as electrodes for applying electrical signals to the elements. Such films could be any suitable conductive material such as silver, a silver alloy, etc.

The piezoelectric elements 20 are selected to possess low cross-coupling to thereby reduce response in unwanted modes of operation and enable use of the elements over a wide band of frequencies without significant sensitive degradation. Suitable piezoelectric material for achieving this characteristic include lead metaniobate and lead titanate, among others.

Conductive strips of material 28 are placed in contact with each of the conductive films 24 on the upper surfaces of the piezoelectric elements 20, with conductive strips 28 extending through the casing to a bus 30 which is coupled to a transmit/receive switch 32. Conductive strips of material 34 (see FIG. 2) are placed in contact with conductive films positioned on the bottom surfaces of each of the piezoelectric elements 20 to extend through the casing also to the bus 30. The conductive strips 28 and 34 could advantageously be strips of silver, copper, etc., held in contact with the conductive films by spot welding, soldering or conductive adhesive. Alternatively, the conductive strips could be strips of flexible elastomer containing conductive (e.g. silver) particles or flakes. This latter arrangement would provide desired flexibility.

An alternative to the two-piece housing or casing 2 of FIG. 1 would be a one-piece housing made, for example, by first supporting the piezoelectric elements, connecting wires, etc., in the desired configuration (using suitable tooling fixtures), and then encapsulating the entire array in

the encasement material.

The circuitry for producing electrical signals to stress the piezoelectric elements 20, and for detecting the occurrence of stress in the elements includes, in addition to the transmit/receive switch 32, a transmitter 36 and receiver and signal processor 38 both connected to the switch 32, a control circuit 40 connected to the transmitter 36, and a display unit 42 connected to the control circuit 40 and receiver and signal processor 38. The control circuit 40, which might illustratively be a microprocessor, signals the transmitter 36 to apply electrical signals via the transmit/receive switch 32 to the piezoelectric elements 20 to stress the elements. The piezoelectric elements 20 are thus caused to produce, for example, sonar signals for underwater transmission. Reflected sonar signals intercepted by the piezoelectric elements 20 stress the elements and cause them to produce electrical signals which are applied via the switch 32 to the receiver and signal processor 38. The receiver and signal processor 38 processes these signals and then signals the display unit to display information representing the location and shape, for example, of underwater objects from which the sonar signals are reflected. The circuitry described is conventional, shown only for illustrative purposes, and does not form any part of the invention.

The overall size of the transducer assembly could be whatever is desired by the user, but would depend in part on the number of piezoelectric elements to be utilized. Advantageously, the piezoelectric elements 20 would have widths and lengths of between about 3 mm and several cm and would have thicknesses of between about 0,25 mm and 25 mm. These dimensions facilitate ease of manufacture and piezoelectric poling. Of course, the smaller the piezoelectric element, the greater would be the flexibility and conformability of the transducer assembly. Employment of a flexible casing 2 for holding the piezoelectric elements serves not only to accommodate the feature of flexibility and conformability, but also serves to isolate and protect the piezoelectric elements 20 from shock, hydrostatic pressures, water and other fluids in which it would be used, and other external effects. With the generally flat profile of the transducer assembly, the assembly can be readily attached to flat mounting surfaces and to surfaces having shapes which are other than planar and which may change over time.

FIG. 2 shows a side, fragmented cross-sectional view of the transducer assembly of FIG. 1 including the base section 4 and cover section 8 of the casing, the piezoelectric elements 20, and a conductive strip 28 attached to the conductive films or electrodes 24 on the top surface of the piezoelectric elements, and a conductive strip 34 at-

tached to the conductive films or electrodes on the bottom surface of the elements.

FIG. 3 shows a top plan view of a fragmented portion of a base section 44 of a casing, where the compartments 48 are formed in a triangular shape to accommodate triangularly-shaped piezoelectric elements. Of course, a variety of other shapes could also be employed as earlier indicated. It is desirable, however, that the piezoelectric elements be closely packed and nested together and this is accommodated by either the rectangular or triangular shape.

FIG. 4 shows a side, fragmented cross-sectional view of a transducer assembly wherein sheets of conductive material 54 and 58 are respectively placed to contact all of the individual conductive films placed on the upper surfaces of the piezoelectric elements, and to contact all of the films or electrodes on the bottom surfaces of the elements. These conductive sheets would be provided for carrying externally produced signals simultaneously to all of the piezoelectric elements, and for carrying signals produced by all of the elements simultaneously to an external sink. This provision of conductive sheets of material is an alternative to the conductive strips 28 and 34 shown in FIG. 1. Advantageously, the conductive sheets would be made of a composition of conductive particles and an elastomer, to provide flexibility for bending, etc.

Claims

1. A flexible piezoelectric transducer assembly comprising
 - an encasement (2) made of a flexible, resilient material and having a generally flattened side profile, said encasement (2) including a plurality of closely packed compartments (12;48) arranged generally in a plane in the encasement (2), where the compartments (12;48) are polygonal in shape and nested such that adjacent side edges of the compartments (12;48) are generally parallel,
 - a plurality of piezoelectric elements (20) being polygonal in shape and dimensioned so that the elements fit snugly in the compartments and selected to have low cross coupling characteristics, each encapsulated in a different compartment (12;48) of the encasement (2), and
 - conduction means (24,34;54,58;28) coupled through the encasement (2) to the piezoelectric elements (20) for carrying electrical signals to said elements (20) to stress the elements (20), and for carrying electrical signals produced by said elements (20) when said elements (20) are stressed.

2. A transducer assembly as in Claim 1 wherein said encasement (2) is formed of a generally planar base section (4;44) upper side of which is formed with said compartments (12;48), and a top section (8) for placement on the upper side of the base section (4;44) to enclose the compartments (12).
3. A transducer assembly as in Claim 1 or 2 wherein said encasement (12) is made of polyurethane.
4. A transducer assembly as in Claim 1 or 2 wherein said encasement (2) is made of polyethelene.
5. A transducer assembly as in Claim 1 or 2 wherein said encasement (2) is made of rubber.
6. A transducer assembly as in Claim 1 wherein the compartments (12) and piezoelectric elements (20) are generally rectangular in shape.
7. A transducer assembly as in Claim 1 wherein the compartments (48) and piezoelectric elements are generally triangular in shape.
8. A transducer assembly as in Claim 1 wherein the piezoelectric elements (20) are made of lead titanate.
9. A transducer assembly as in Claim 1 wherein the piezoelectric elements (20) are made of lead metaniobate.
10. A transducer assembly as in any one of Claims 1 to 6 wherein the piezoelectric elements (20) are formed generally in squares having a thickness of from about 0,25 mm to 25 mm, and a width of from about 3 mm to about 100 mm.
11. A transducer assembly as in any one of the preceding Claims wherein the piezoelectric elements (20) are held in place in the compartments (12;48) by an adhesive.
12. A transducer assembly as in any one of the preceding Claims wherein the conduction means comprises
 - conductive sheets (24,34) disposed on opposing sides of piezoelectric elements (20), and
 - conductive strips (28) of material placed in contact with the conductive sheets (24,34) and extending through the encasement (2) to carry electrical signals from an external source (36)

to the sheets (24,34), and from the sheets (24,34) to external electronics (38).

13. A transducer assembly as in Claim 12 wherein said conductive strips (28) are composed of a composition of conductive particles and elastomer.

14. A transducer assembly as in any one of Claims 1 to 11 wherein the conduction means comprises

a first sheet (54) of conductive material disposed in contact with one side of each of the piezoelectric elements (20),

a second sheet (58) of conductive material disposed in contact with the other side of each of the piezoelectric elements (20), and

conductors for carrying electrical signals from an external source (36) to the first and second sheets (54,58) of material, and from the first and second sheets (54,58) to external electronics (38).

Revendications

1. Dispositif transducteur piézo-électrique flexible comprenant :

- un boîtier (2) formé d'une matière élastique flexible et présentant un profil latéral généralement aplati, ce boîtier (2) comportant une multiplicité de compartiments (12,48) étroitement tassés, disposés généralement dans un plan dans le boîtier (2), ces compartiments (12,48) ayant une forme polygonale et étant serrés de telle sorte que des bords latéraux adjacents des compartiments (12,48) soient généralement parallèles;

- une multiplicité d'éléments piézo-électriques (20), de forme polygonale, dimensionnés de telle sorte que ces éléments se logent étroitement dans les compartiments et étant choisis pour avoir de faibles caractéristiques de couplage transversal, chacun étant encapsulé dans un compartiment différent (12,48) du boîtier (2); et

- des moyens de conduction (24,34;54,58;28) couplés à travers le boîtier (2) aux éléments piézo-électriques (20) pour transmettre des signaux électriques à ces éléments (20) pour contraindre les éléments (20), et pour transmettre les signaux électriques produits par les éléments (20) lorsque ceux-ci sont contraints.

2. Dispositif transducteur selon la revendication 1,

dans lequel le boîtier (2) est formé d'une section de base généralement plane (4;44), dont une face supérieure est formée avec les compartiments (12;48), et d'une section supérieure (8) propre à être placée sur la face supérieure de la section de base (4;44) pour fermer les compartiments (12).

3. Dispositif transducteur selon la revendication 1 ou la revendication 2, dans lequel le boîtier (2) est formé de polyuréthane.

4. Dispositif transducteur selon la revendication 1 ou la revendication 2, dans lequel le boîtier (2) est formé de polyéthylène.

5. Dispositif transducteur selon la revendication 1 ou la revendication 2, dans lequel le boîtier (2) est formé de caoutchouc.

6. Dispositif transducteur selon la revendication 1, dans lequel les compartiments (12) et les éléments piézo-électriques (20) ont une forme générale rectangulaire.

7. Dispositif transducteur selon la revendication 1, dans lequel les compartiments (48) et les éléments piézo-électriques ont une forme généralement triangulaire.

8. Dispositif transducteur selon la revendication 1, dans lequel les éléments piézo-électriques (20) sont en titanate de plomb.

9. Dispositif transducteur selon la revendication 1, dans lequel les éléments piézo-électriques (20) sont en métaniobate de plomb.

10. Dispositif transducteur selon l'une des revendications 1 à 6, dans lequel les éléments piézo-électriques (20) sont formés généralement en carrés ayant une épaisseur comprise entre environ 0,25 mm et 25 mm, et une largeur comprise entre environ 3 mm et environ 100 mm.

11. Dispositif transducteur selon l'une quelconque des revendications précédentes, dans lequel les éléments piézo-électriques (20) sont maintenus en place dans les compartiments (12;48) par un adhésif.

12. Dispositif transducteur selon l'une quelconque des revendications précédentes, dans lequel les moyens de conduction comprennent :

- des feuilles conductrices (24,34) disposées sur des faces opposées des éléments piézo-électriques (20), et
- des bandes d'une matière conductrice

(28) placées au contact des feuilles conductrices (24,34) et s'étendant à travers le boîtier (2) pour transmettre des signaux électriques d'une source extérieure (36) aux feuilles (24,34), et des feuilles (24,34) à une électronique extérieure (38).

13. Dispositif transducteur selon la revendication 12, dans lequel les bandes conductrices (28) sont constituées d'une composition de particules conductrices et d'élastomère.

14. Dispositif transducteur selon l'une quelconque des revendications 1 à 11, dans lequel les moyens de conduction comprennent :

- une première feuille (54) de matière conductrice disposée en contact avec une face de chacun des éléments piézo-électriques (20),
- une deuxième feuille (58) de matière conductrice disposée en contact avec l'autre face de chacun des éléments piézo-électriques (20), et
- des conducteurs pour transmettre des signaux électriques en provenance d'une source extérieure (36) aux première et deuxième feuilles (54,58) de matière, et des première et deuxième feuilles (54,58) à une électronique extérieure (38).

Patentansprüche

1. Flexible piezoelektrische Wandleranordnung, enthaltend

ein Gehäuse (2) aus einem flexiblen, nachgiebigen Material und im wesentlichen flachen Seitenprofil, welches Gehäuse (2) mehrere eng benachbarte Abteile (12;48) enthält, die im wesentlichen in einer Ebene in dem Gehäuse (2) angeordnet sind, wobei die Abteile (12;48) eine polygonale Gestalt aufweisen und derart angeordnet sind, daß benachbarte Seitenränder der Abteile (12;48) im wesentlichen parallel sind,

mehrere piezoelektrische Elemente (20), die eine polygonale Gestalt aufweisen und derart bemessen sind, daß die Elemente eng in die Abteile passen, und die derart ausgewählt sind, daß sie niedrige Übersprechkopplungseigenschaften aufweisen, jedes in einem anderen Abteil (12;48) des Gehäuses (2) angeordnet, und

Leitereinrichtungen (24,34;54,58;28), die durch das Gehäuse (2) mit den piezoelektrischen Elementen (20) verbunden sind, um elektrische

Signale den genannten Elementen (20) zuzuführen, um die Elemente (20) zu belasten, und zum Fortführen elektrischer Signale, die von den Elementen (20) erzeugt werden, wenn die Elemente (20) belastet werden.

2. Wandleranordnung nach Anspruch 1, bei der das Gehäuse (2) aus einem im wesentlichen ebenen Basisteil (4;44), dessen Oberseite mit den Abteilen (12;48) versehen ist und einem Deckteil (8) zum Aufsetzen auf die Oberseite des Basisteils (4;44) zum Verschließen der Abteile (12) besteht.

3. Wandleranordnung nach Anspruch 1 oder 2, bei der das Gehäuse (2) aus Polyurethan besteht.

4. Wandleranordnung nach Anspruch 1 oder 2, bei der das Gehäuse (2) aus Polyethylen besteht.

5. Wandleranordnung nach Anspruch 1 oder 2, bei der das Gehäuse (2) aus Gummi besteht.

6. Wandleranordnung nach Anspruch 1, bei der die Abteile (12) und die piezoelektrischen Elemente (20) im wesentlichen rechteckige Gestalt haben.

7. Wandleranordnung nach Anspruch 1, bei der die Abteile (48) und die piezoelektrischen Elemente im wesentlichen dreieckige Gestalt haben.

8. Wandleranordnung nach Anspruch 1, bei der die piezoelektrischen Elemente (20) aus Bleititanat bestehen.

9. Wandleranordnung nach Anspruch 1, bei der die piezoelektrischen Elemente (20) aus Bleimetaniobat bestehen.

10. Wandleranordnung nach einem der Ansprüche 1 bis 6, bei der die piezoelektrischen Elemente (20) im wesentlichen quadratisch sind und eine Dicke von etwa 0,25 mm bis etwa 25 mm aufweisen und eine Breite von etwa 3 mm bis etwa 100 mm haben.

11. Wandleranordnung nach einem der vorhergehenden Ansprüche, bei der die piezoelektrischen Elemente (20) in den Abteilen (12;48) durch einen Klebstoff festgehalten werden.

12. Wandleranordnung nach einem der vorhergehenden Ansprüche, bei der die Leitereinrichtung enthält:

leitfähige Folien (24,34), die auf gegenüberliegende Seiten der piezoelektrischen Elemente (20) angeordnet sind, und

5

leitfähige Materialstreifen (28), die mit den leitfähigen Folien (24,34) in Berührung sind und sich durch das Gehäuse (2) erstrecken, um elektrische Signale von einer äußeren Quelle (36) zu den Folien (24,34) zu führen und von den Folien (24,34) zu äußeren elektronischen Einrichtungen (38) zu führen.

10

13. Wandleranordnung nach Anspruch 12, bei der die leitfähigen Streifen (28) aus einer Zusammensetzung aus leitfähigen Partikeln und einem Elastomer bestehen.

15

14. Wandleranordnung nach einem der Ansprüche 1 bis 11, bei der die Leitereinrichtung enthält:

20

eine erste Folie (54) aus einem leitfähigen Material, die mit einer Seite eines jeden der piezoelektrischen Elemente (20) in Berührung ist,

25

eine zweite Folie (58) aus leitfähigem Material, die mit der anderen Seite eines jeden der piezoelektrischen Elemente (20) in Berührung ist, und

30

Leiter zum Zuführen elektrischer Signale von einer äußeren Quelle (36) zu den ersten und zweiten Materialfolien (54,58) und von den ersten und zweiten Folien (54,58) zu äußeren elektronischen Einrichtungen (38).

35

40

45

50

55

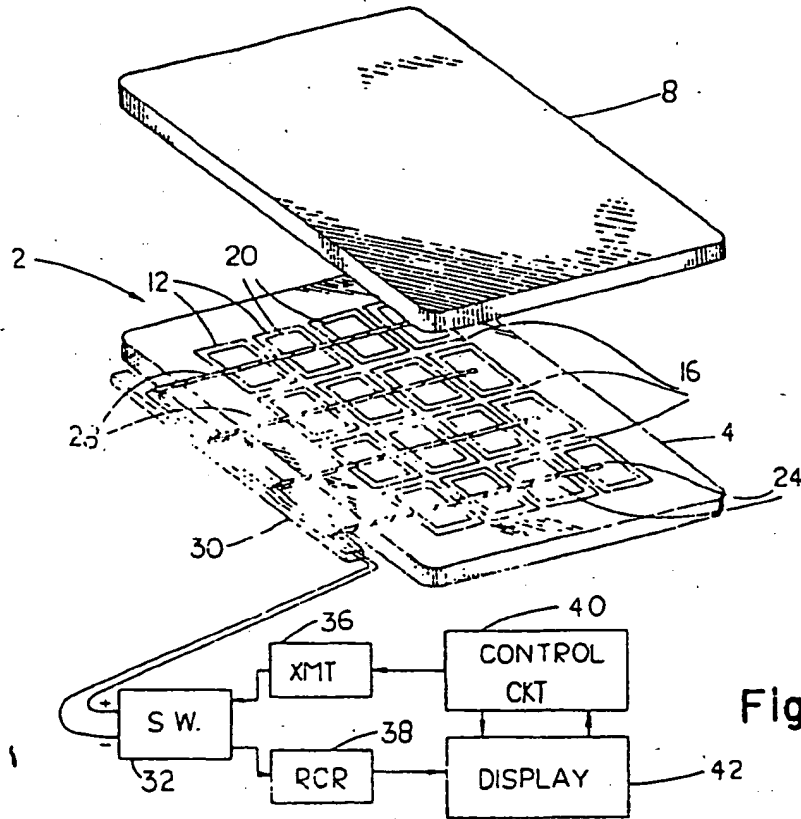

Fig. 1

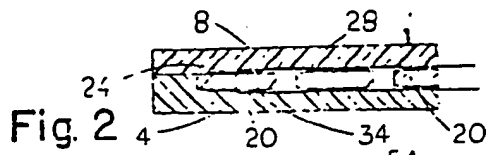

Fig. 2

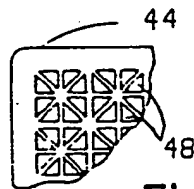

Fig. 3

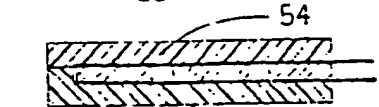

Fig. 4